

Inhaltsverzeichnis

Index

Seite/Page

Flexitool - Einsatzmöglichkeiten	2
Flexitool 1,5 x D	3
Flexitool 2,25 x D	4
Flexitool 3 x D	5
Wendeschnidplatten <i>indexable inserts</i>	6
FT - Einsatzwerte/ cutt. Datas	7
Kurzklemmhalter <i>cartridges</i>	11
Eckfräser <i>shank mill</i>	14
Senk - Faswerkzeug <i>chamfering tool</i>	15
Bohrstangen <i>boring bars</i>	16
Sonderwerkzeuge <i>special tools</i>	17
Anfrageformular <i>technical questionnaire</i>	18
Mappe Sonderwerkzeuge <i>special tools</i>	
Mappe Projekt Anschlussstutzen <i>project pipe connection</i>	

Einsatzmöglichkeiten

How to be use.

1. Bohren / drilling

Bohren ins Volle mit ebenem Bohrungsgrund
Drilling with flat bottom face

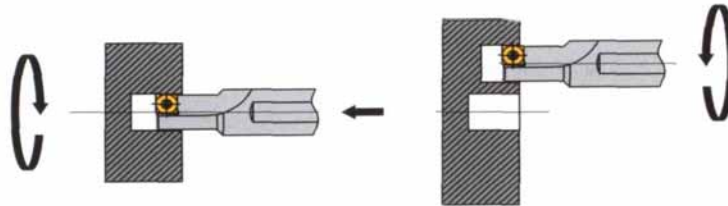

2. Drehen / turning

Drehen von Innenkonturen
Turning of internal profiles

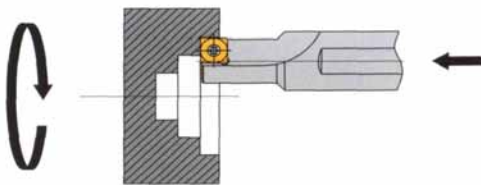

Drehen von Außenkonturen
Turning of external profiles

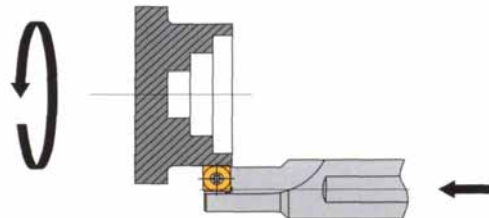

Drehen von Plankonturen
Facing operations

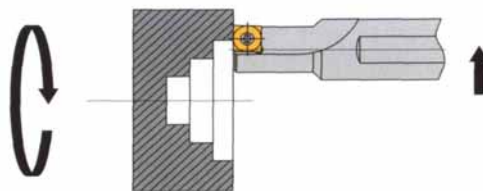

Flexitool 1,5

Bohrtiefen bis

Drilling depth up to
Profondeur de perçage jusqu' à

1,5 x D

Ø 8 - 32 mm

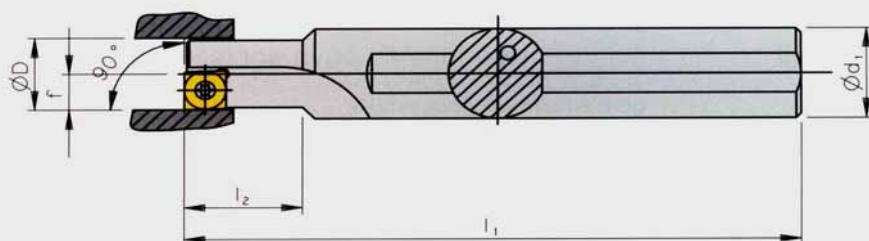

Rechte Ausführung abgebildet
Right-hand execution shown
Outil représenté à droite

Bezeichnung Designation	BStNR rechts right hand	Preis €/St.	BSTNR links left hand	Preis €/St.	Ø D	Ø d ₁	L ₁	L ₂	f	Platte insert
FT 8 x 1,5D R/L	FTR15083367	111,00	FTL15083368	111,00	8	10	80	12	4	XC..T 0401...
FT 10 x 1,5D R/L	FTR15103369	111,00	FTL15103370	111,00	10	12	90	15	5	XC..T 0502...
FT 12 x 1,5D R/L	FTR15123371	116,00	FTL15123372	116,00	12	16	100	18	6	XC..T 0602..
FT 14 x 1,5D R/L	FTR15143647	116,00	FTL15143648	116,00	14	16	110	21	7	XC..T 070304
FT 16 x 1,5D R/L	FTR15163361	137,00	FTL15163519	137,00	16	20	125	24	8	XC..T 080304
FT 18 x 1,5D R/L	FTR15183649	137,00	FTL15183650	137,00	18	25	135	27	9	XC..T 09T304
FT 20 x 1,5D R/L	FTR15203373	150,00	FTL15203374	150,00	20	25	150	30	10	XC..T 10T3...
FT 25 x 1,5D R/L	FTR15253375	174,00	FTL15253376	174,00	25	32	180	38	12,5	XC..T 1304...
FT 32 x 1,5D R/L	FTR15323378	197,00	FTL15323377	197,00	32	40	200	48	16	XC..T 170508

¹⁾ **Rechter Halter - Rechte Wendeplatte**
right hand holder right hand insert

¹⁾ **Linker Halter - Linke Wendeplatte**
left hand holder left hand insert

Ersatzteile/Spare parts

Halter Holder	Schraube screw / Torx
FT 8 x 3D R/L	M1,8 x 3,3 T06
FT 10 x 3D R/L	M2,0 x 4,0 T06
FT 12 x 3D R/L	M2,2 x 5,0 T07
FT 14 x 3D R/L	M2,5 x 5,0 T08
FT 16 x 3D R/L	M3,0 x 7,3 T08
FT 18 x 3D R/L	M3,0 x 7,3 T08
FT 20 x 3D R/L	M3,5 x 8,6 T15
FT 25 x 3D R/L	M4,5 x 8,6 T15
FT 32 x 3D R/L	M4,5 x 8,6 T15

Lieferumfang: mit Klemmschraube
Holder will be supplied with one clamping screw

Auch andere Abmessungen auf Anfrage lieferbar. Other
Dimensions on request available.

Flexitool 2,25

Bohrtiefen bis

Drilling depth up to

Profondeur de perçage jusqu' à

2,25 x D

Ø 8 - 32 mm

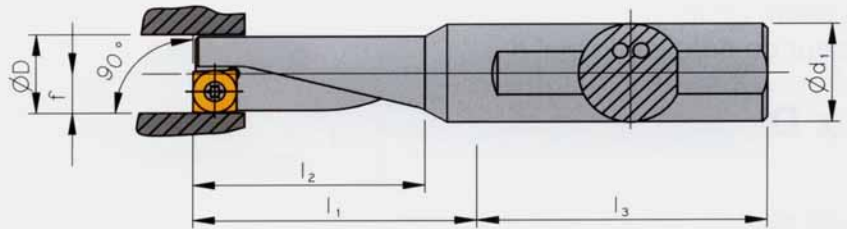

Rechte Ausführung abgebildet
Right-hand execution shown
Outil représenté à droite

Bezeichnung Designation	BStNR rechts right hand	Preis €/St.	BSTNR links left hand	Preis €/St.	Ø D	Ø d ₁	L1	L2	L3	Platte insert
FT 8 x 2,25D R/L ¹⁾	FTR225083651	159,00	FTL225083652	159,00	8	10	22	18	38	XC..T 0401...
FT 10 x 2,25D R/L	FTR225103653	159,00	FTL225103654	159,00	10	12	27,5	22,5	42	XC..T 0502...
FT 12 x 2,25D R/L	FTR225123371	167,00	FTL225123655	167,00	12	16	33	27	45	XC..T 0602..
FT 14 x 2,25D R/L	FTR225143656	167,00	FTL225143657	167,00	14	16	38,5	31,5	45	XC..T 070304
FT 16 x 2,25D R/L	FTR225163658	188,00	FTL225163659	188,00	16	20	44	44	50	XC..T 080304
FT 18 x 2,25D R/L	FTR225183660	188,00	FTL225183661	188,00	18	25	53,5	40,5	56	XC..T 09T304
FT 20 x 2,25D R/L	FTR225203662	200,00	FTL225203663	200,00	20	25	55	45	56	XC..T 10T3...
FT 25 x 2,25D R/L	FTR225253664	231,00	FTL225253665	231,00	25	32	82	56,5	60	XC..T 1304...
FT 32 x 2,25D R/L	FTR225323666	260,00	FTL225323667	260,00	32	40	88	72	70	XC..T 170508

¹⁾ Rechter Halter - Rechte Wendeplatte
right hand holder right hand insert

¹⁾ Linker Halter - Linke Wendeplatte
left hand holder left hand insert

Ersatzteile/Spare parts

Halter Holder	Schraube screw / Torx
FT 8 x 3D R/L	M1,8 x 3,3 T06
FT 10 x 3D R/L	M2,0 x 4,0 T06
FT 12 x 3D R/L	M2,2 x 5,0 T07
FT 14 x 3D R/L	M2,5 x 5,0 T08
FT 16 x 3D R/L	M3,0 x 7,3 T08
FT 18 x 3D R/L	M3,0 x 7,3 T08
FT 20 x 3D R/L	M3,5 x 8,6 T15
FT 25 x 3D R/L	M4,5 x 8,6 T15
FT 32 x 3D R/L	M4,5 x 8,6 T15

Lieferumfang: mit Klemmschraube
Holder will be supplied with one clamping screw

**Auch andere Abmessungen auf Anfrage lieferbar. Other
Dimensions on request available.**

Flexitool - Schwermetall (Densimet)

Flexitool - heavy metal

Bohrtiefen bis

Drilling depth up to

Profondeur de perçage jusqu' à

3 x D

Ø 8 - 32 mm

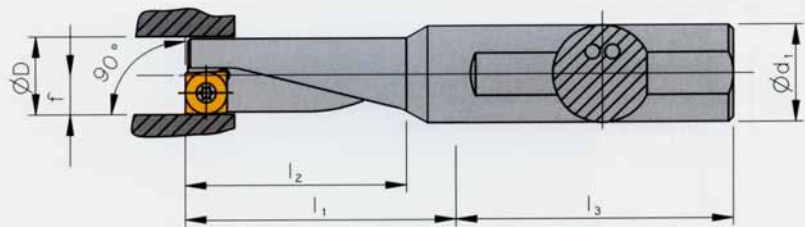

Rechte Ausführung abgebildet
Right-hand execution shown
Outil représenté à droite

Bezeichnung Designation	BStNR rechts right hand	Preis €/St.	BSTNR links left hand	Preis €/St.	Ø D	Ø d ₁	L1	L2	L3	Platte insert
Densimet										
FT 8 x 3D R/L ¹⁾	FTR3083506	341,--	FTL3083524	341,--	8	12	80	24	38	XCNT 0401...
FT 10 x 3D R/L	FTR3103525	341,--	FTL3103526	341,--	10	12	90	30	42	XC...T 0502...
FT 12 x 3D R/L	FTR3123528	368,--	FTL3123527	368,--	12	14	100	35	45	XC..T 0602..
FT 14 x 3D R/L	FTR3143530	376,--	FTL3143529	376,--	14	16	110	42	45	XC..T 070304
FT 16 x 3D R/L	FTR3163507	413,--	FTL3163531	413,--	16	18	125	48	50	XC..T 080304
FT 18 x 3D R/L	FTR3183533	499,--	FTL3183532	499,--	18	20	135	74	56	XC..T 09T304
FT 20 x 3D R/L	FTR3203534	510,--	FTL3203504	510,--	20	25	150	60	56	XC..T 10T3...
FT 25 x 3D R/L	FTR3253505	649,--	FTL3253535	649,--	25	32	180	75	60	XC..T 1304...
FT 32 x 3D R/L	FTR3323537	852,--	FTL3323536	852,--	32	40	200	96	70	XC..T 170508

¹⁾ **Rechter Halter - Rechte Wendeplatte**
right hand holder right hand insert

¹⁾ **Linker Halter - Linke Wendeplatte**
left hand holder left hand insert

Ersatzteile/Spare parts

Halter Holder	Schraube screw / Torx
FT 8 x 3D R/L	M1,8 x 3,3 T06
FT 10 x 3D R/L	M2,0 x 4,0 T06
FT 12 x 3D R/L	M2,2 x 5,0 T07
FT 14 x 3D R/L	M2,5 x 5,0 T08
FT 16 x 3D R/L	M3,0 x 7,3 T08
FT 18 x 3D R/L	M3,0 x 7,3 T08
FT 20 x 3D R/L	M3,5 x 8,6 T15
FT 25 x 3D R/L	M4,5 x 8,6 T15
FT 32 x 3D R/L	M4,5 x 8,6 T15

Lieferumfang: mit Klemmschraube
Holder will be supplied with one clamping screw

Auch andere Abmessungen auf Anfrage lieferbar.
Other Dimensions on request available.

Lieferzeit ca. 4 AW
Delivery time appr. 4 weeks

XCNT oder XCET verwendbar

Wendeplatten / Indexable inserts

XCET...
XCNT...

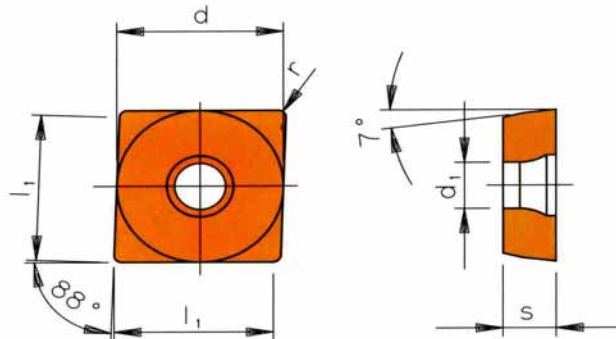

Wendeschneidplatte / Indexable inserts

Bezeichnung Designation	l ₁	d	s	r	d ₁	unbeschichtet / uncoated		
						K10		
	XCET 040104 FL	4,0	4,5	1,80	0,4	2,10	●	
	XCET 040104 FR	4,0	4,5	1,80	0,4	2,10	●	
	XCET 050204 FN	4,0	5,8	21,0	0,4	2,25	●	
	XCET 060204 FN	6,0	6,5	2,38	0,4	2,50	●	
	XCET 070304 FN	7,0	7,6	3,18	0,4	2,80	●	
	XCET 080304 FN	8,0	8,5	3,18	0,4	3,40	●	
	XCET 09T304 FN	9,0	9,6	3,97	0,4	3,40	●	
	XCET 10T304 FN	10,0	10,6	3,97	0,4	4,40	●	
	XCET 130404 FN	12,5	13,5	4,76	0,4	5,30	●	
	XCET 170508 FN	16,0	17,5	5,56	0,8	5,30	●	

Bezeichnung Designation	l ₁	d	s	r	d ₁	beschichtet / coated			unbeschichtet / uncoated		
						Multilayer TiAlN	Multilayer TiCN	Aluminiumoxid	P40		
	XCNT 040102 ER/EL *	4,0	4,5	1,80	0,2	2,10	●	●	●	●	
	XCNT 040104 ER/EL	4,0	4,5	1,80	0,4	2,10	●	●	●	●	
	XCNT 050202 EN	5,0	5,8	2,10	0,2	2,25	●	●	●	●	
	XCNT 050204 EN	5,0	5,8	2,10	0,4	2,25	●	●	●	●	
	XCNT 060202 EN	6,0	6,5	2,38	0,2	2,50	●	●	●	●	
	XCNT 060204 EN	6,0	6,5	2,38	0,4	2,50	●	●	●	●	
	XCNT 070304 EN	7,0	7,6	3,18	0,4	2,80	●	●	●	●	
	XCNT 080304 EN	8,0	8,5	3,18	0,4	3,40	●	●	●	●	
	XCNT 09T304 EN	9,0	9,6	3,97	0,4	3,40	●	●	●	●	
	XCNT 10T304 EN	10,0	10,6	3,97	0,4	4,40	●	●	●	●	
	XCNT 10T308 EN	10,0	10,6	3,97	0,8	4,40	●	●	●	●	
	XCNT 130404 EN	12,5	13,5	4,76	0,4	5,30	●	●	●	●	
	XCNT 130408 EN	12,5	13,5	4,76	0,8	5,30	●	●	●	●	
	XCNT 170508 EN	16,0	17,5	5,56	0,8	5,30	●	●	●	●	

● Rechter Halter - Rechte Wendeschneidplatte
Linker Halter - Linke Wendeschneidplatte.

● Right-hand holder - Right-hand indexable insert
Left-hand holder - Left-hand indexable insert.

Auch Platten anderer Hersteller verwendbar / inserts from other suppliers suitable

für ECOUT

Einsatzrichtlinien Bohren

cutting datas drilling

Werkstück- Werkstoff	Legierung / Behandlungsart		Härte HB	v _c (m/min)		
				Alumi- niumoxid	TICN Multi- layer	unbeschichtet uncoated
unlegierter Stahl	C ≤ 0,15%	geglüht	125	140 – 250	150 – 280	80 – 140
	C 0,15% – 0,45%	geglüht	150 – 250	100 – 180	120 – 200	70 – 100
	C ≥ 0,45%	vergütet	300	80 – 150	100 – 180	60 – 100
niedriglegierter Stahl		geglüht	180	100 – 180	120 – 200	60 – 100
		vergütet	250 – 300	80 – 150	90 – 160	50 – 90
		vergütet	350	70 – 120	80 – 140	50 – 80
hochlegierter Stahl		geglüht	200	100 – 160	110 – 180	60 – 80
		vergütet	350	60 – 120	80 – 140	—
nichtrostender Stahl	ferritisch	geglüht	200	100 – 180	—	60 – 80
	martensitisch	vergütet	325	80 – 150	—	50 – 80
rostfreier Stahl	austenitisch	abgeschreckt	180	100 – 180	—	60 – 100
Grauguß	perlitisch / ferritisch		180	—	120 – 200	—
	perlitisch / martensitisch		260			
Grauguß mit Kugelgraphit	ferritisch		160	—	110 – 200	—
	perlitisch		250			
Temperguß	ferritisch		130	—	100 – 200	—
	perlitisch		230			
Aluminium-Knetlegierungen		nicht aushärtbar aushärtbar	60 100	100 – 500	—	100 – 500
Aluminium-Gußlegierungen	< 12% Si	nicht aushärtbar	80	100 – 300	—	100 – 300
	< 12% Si	aushärtbar	90	100 – 250		100 – 200
	> 12% Si	nicht aushärtbar	130	100 – 200		—
Kupfer und Kupferlegierungen (Bronze, Messing)	Automatenlegierungen (Pb 1%)			100 – 500	—	100 – 300
	Messing, Rotguß		90			
	Bronze, bleifreies Kupfer und Elektrolytkupfer		100			

f (mm/U)

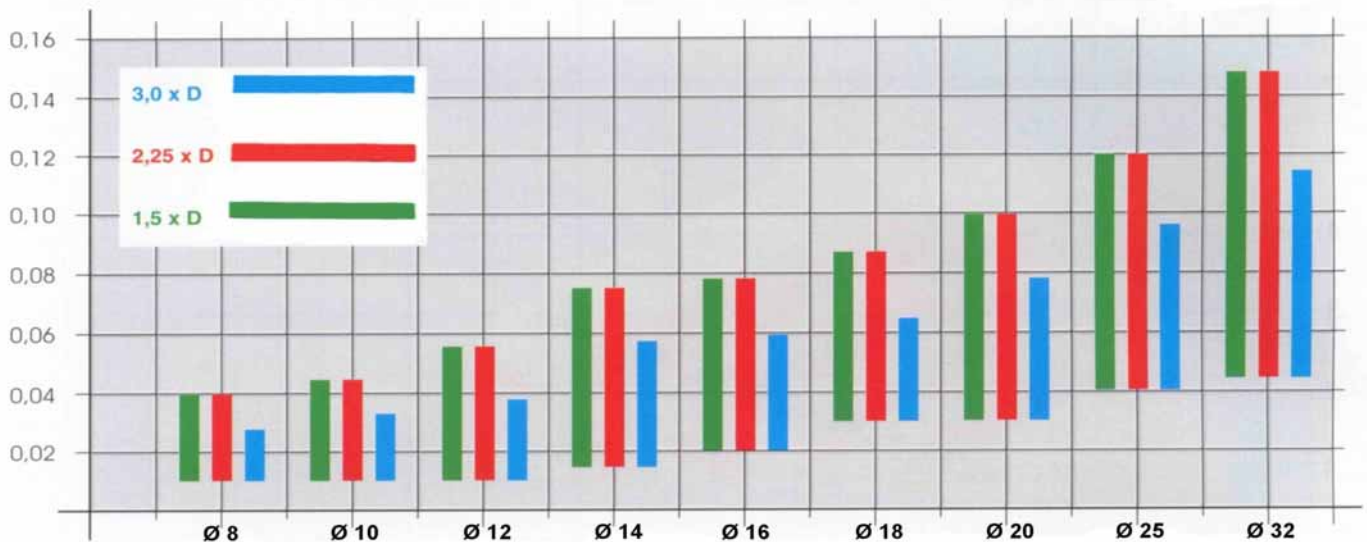

Einsatzrichtlinien Drehen

cutting datas turning

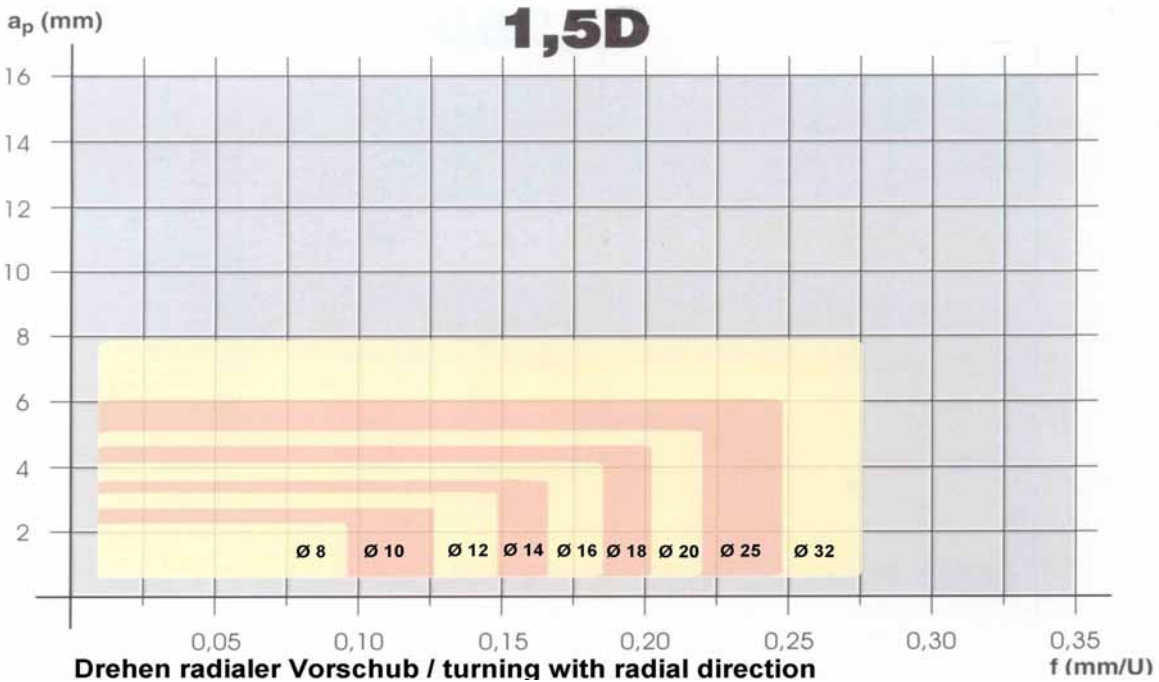
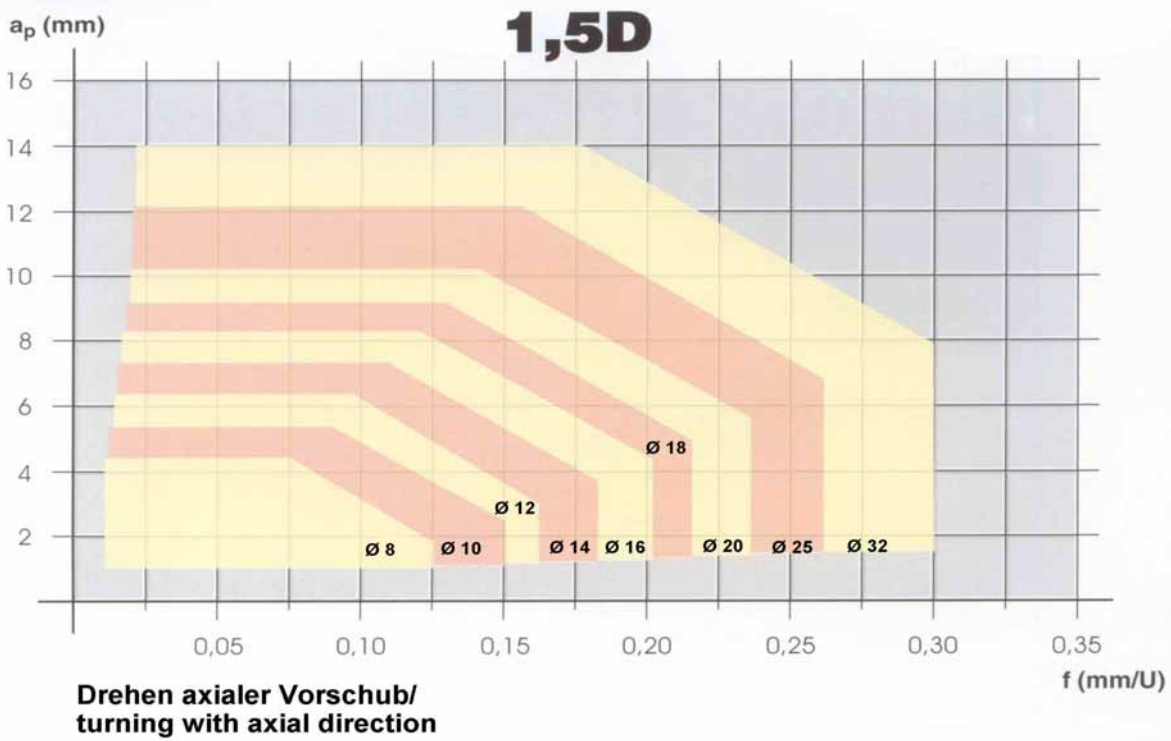

V_c Werte Bohren verwenden / Cut. speed use drill datas

Einsatzrichtlinien Drehen

cutting datas turning

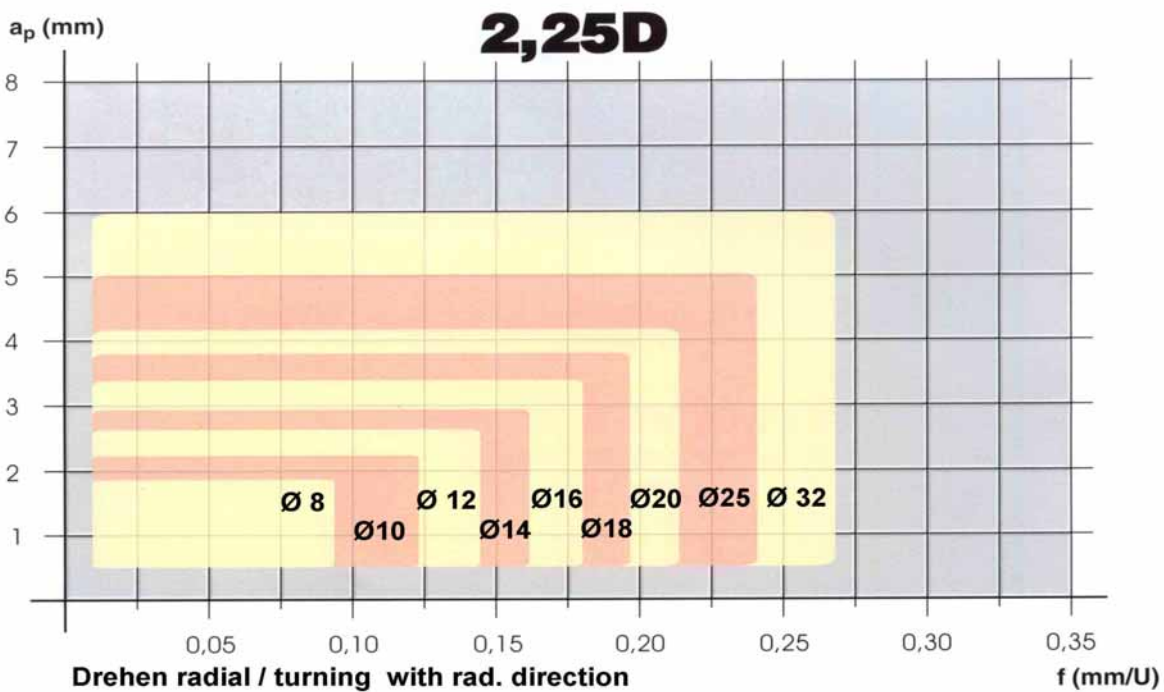
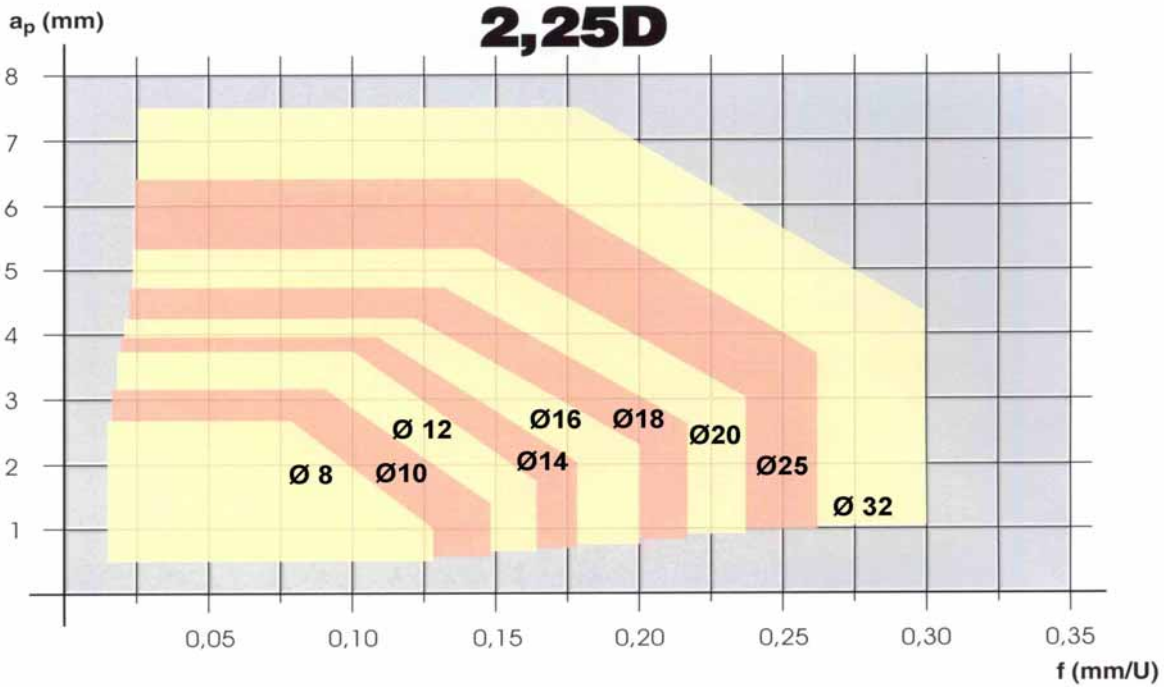

V_c Werte Bohren verwenden / Cut. speed use drill datas

Einsatzrichtlinien Drehen

cutting datas turning

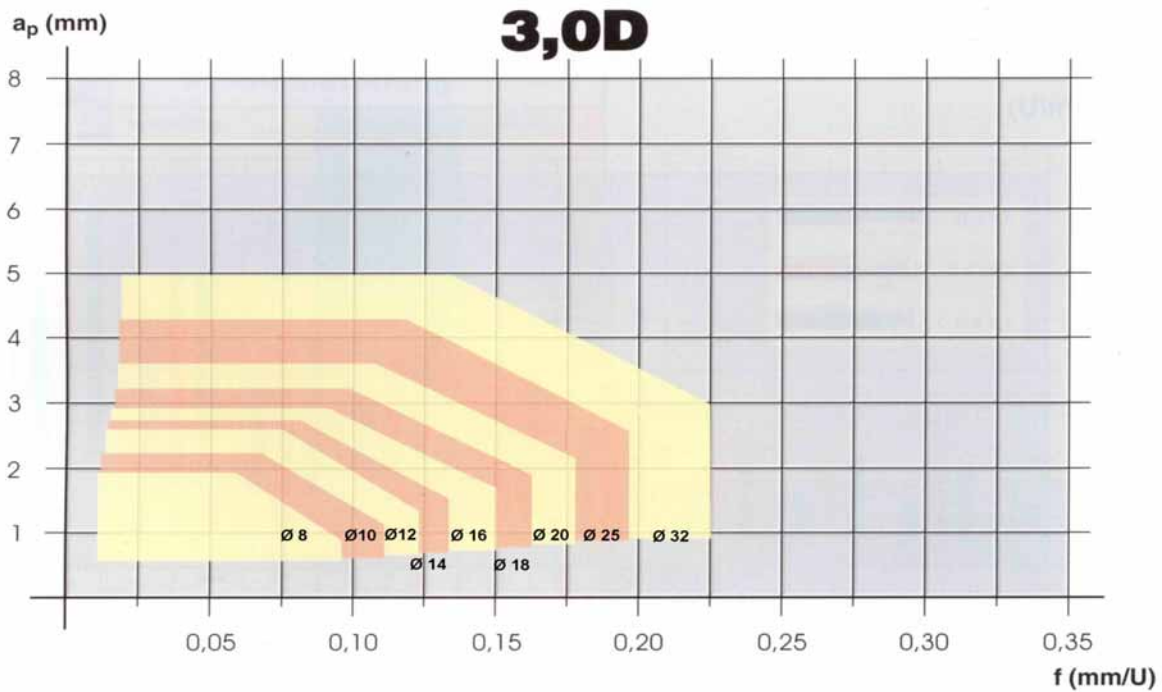

Drehen axial / turning with ax. direction

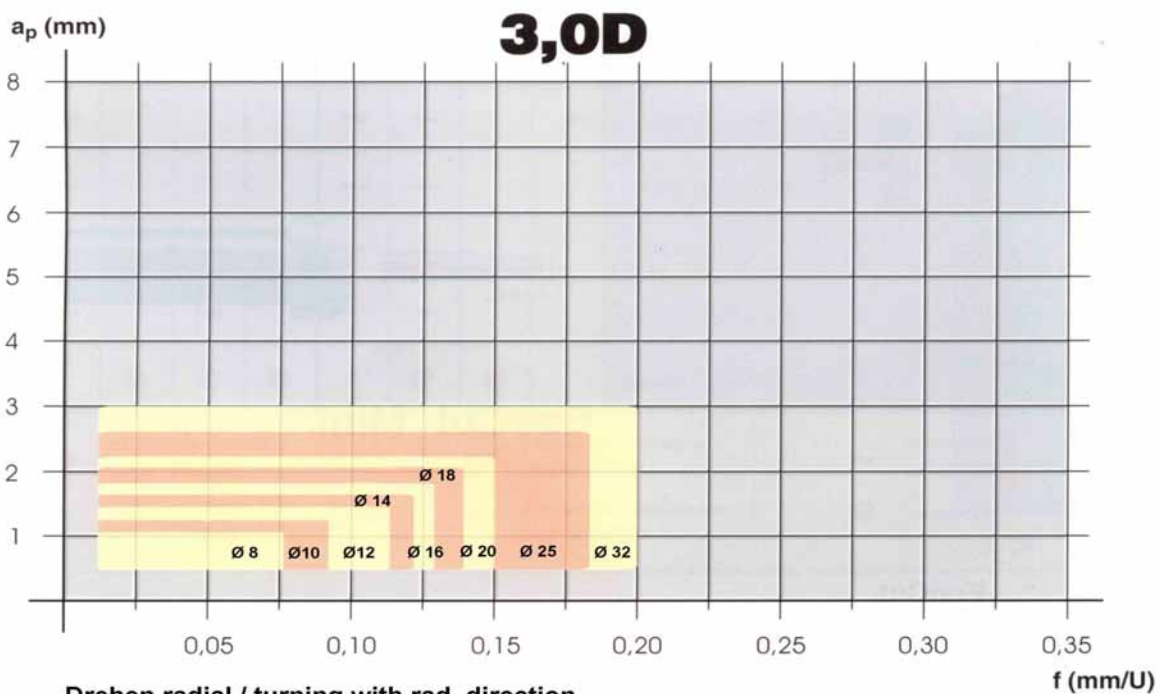

Drehen radial / turning with rad. direction

V_C Werte Bohren verwenden / Cut. speed use drill datas

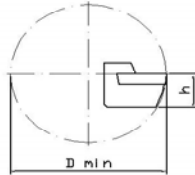
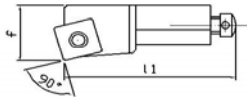

**Einbauhalter
Kurzklemmhalter
Cartridges**

**Klemmsystem Schraube
Clamping system Screw**

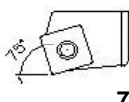
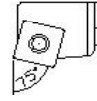
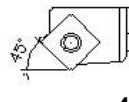

15°(75°),45°, 75°, 85°

für SCMT 090304/120404
für SCMT 090308/120408

	Bezeichnung Designation	Art.Nr / Code		Plattengröße Index. inserts	D min	h	f	l1	Preis		
		R	L						2St	ab 5	ab 15
 75°	SSKCR10CA09	8300	8301	SC...0903...	40	10	14	50	97 €	82 €	75 €
	SSKCR10CA09-T3	8303	8304	SC...09T3...	40	10	14	50	97 €	82 €	75 €
	SSKCR12CA12	8306	8307	SC...1204...	50	12	20	55	108 €	99 €	83 €
 75°	SSRCR10CA09	8309	8310	SC...0903...	40	10	14	50	97 €	82 €	75 €
	SSRCR10CA09-T3	8312	8313	SC...09T3...	40	10	14	50	97 €	82 €	75 €
	SSRCR12CA12	8315	8316	SC...1204...	50	12	20	55	108 €	99 €	83 €
 45°	SSSCR10CA09	8318	8319	SC...0903...	40	10	14	44	82 €	82 €	75 €
	SSSCR10CA09-T3	8321	8322	SC...09T3...	40	10	14	44	97 €	82 €	75 €
	SSSCR12CA12	8324	8325	SC...1204...	50	12	20	47	108 €	99 €	83 €
 85°	SSYCR10CA09	8327	8328	SC...0903...	40	10	14	50	97 €	82 €	75 €
	SSYCR10CA09-T3 SS	8330	8331	SC...09T3...	40	10	14	50	97 €	82 €	75 €
	SSYCR12CA12 SSYC	8333	8334	SC...1204...	50	12	20	55	108 €	99 €	83 €

**Lieferzeit ab Lager
Zwischenverkauf vorbehalten**
delivery time from stock

**Zwischenmaße/Sonderausführung möglich/special on request
passende Bohrstangen jederzeit/suitable boring bars o.request**

Lieferumfang: mit allen Einbauteilen
Holder will be supplied complete



Hindenburgstr. 9/1
D-89610 Oberdischingen
Telefon (0 73 05) 95 66 29-0
Telefax (0 73 05) 95 66 29-9
IR-tools@t-online.de
www.IR-tools.de

**Einbauhalter
Kurzklammhalter
Cartridges**

**Klemmsystem Schraube
Clamping system Screw**

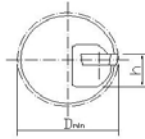
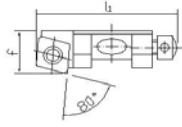

SC.. 45°, 60°, 75°, 90°, 95°

für CCMT 060204/090304

für CCMT 060208 090308

	Bezeichnung Designation	Art.Nr / Code		Plattengröße Index. inserts	Dmin	h	f	l1	Preis		
		R	L						2-5	ab 5	ab 15
	SCFCR07CA06	8033	8034	CC...0602...	20	7	9	28	74 €	58 €	44 €
	SCFCR08CA06 S	8035	8036	CC...0602...	25	8	10	32	74 €	58 €	44 €
	SCFCR10CA09T3	8037	8038	CC...09T3...	40	10	14	50	97 €	82 €	75 €
	SCFCR10CA09	8039	8040	CC...0903...	40	10	14	50	82 €	82 €	69 €
	SCFCR12CA12	8042	8043	CC...1204...	50	12	20	55	108 €	99 €	83 €
	SCLCR06CA05	8041	8042	CP...0502...	20	6	8	25	74 €	58 €	44 €
	SCLCR07CA06	8043	8044	CC...0602...	20	7	9	28	74 €	58 €	44 €
	SCLCR08CA06	8045	8046	CC...0602...	25	8	10	32	74 €	58 €	44 €
	SCLCR10CA09	8047	8048	CC...0903...	40	10	14	50	97 €	82 €	69 €
	SCLCR10CA09T3	8049	8050	CC...09T3...	40	10	14	50	97 €	82 €	75 €
SCLCR12CA12	8051	8052	CC...1204...	50	12	20	55	94 €	99 €	83 €	
	SCGPR06CA05	8060	8063	CP...0502...	20	6	8	25	74 €	58 €	44 €
	SCGCR07CA06	8062	8066	CC...0602...	20	7	9	28	74 €	58 €	44 €
	SCGCR08CA06	8065	8069	CC...0602...	25	8	10	32	74 €	58 €	44 €
	SCGCR10CA09	8068	8072	CC...09T3...	40	10	14	50	97 €	82 €	75 €
	SCGCR12CA12	8071	8075	CC...1204...	50	12	20	55	94 €	99 €	83 €
	SCKPR06CA05 S	8074	8078	CP...0502...	20	6	8	25	74 €	58 €	44 €
	SCKCR07CA06 S	8077	8081	CC...0602...	20	7	9	28	74 €	58 €	44 €
	SCKCR08CA06 S	8080	8084	CC...0602...	25	8	10	32	74 €	58 €	44 €
	SCKCR10CA09 S	8083	8087	CC...09T3...	40	10	14	50	97 €	82 €	75 €
	SCKCR12CA12 S	8086	8090	CC...1204...	50	12	20	55	94 €	99 €	83 €
	SCRPR06CA05	8089	8093	CP...0502...	20	6	8	25	74 €	58 €	44 €
	SCRCR08CA06	8092	8096	CC...0602...	25	8	10	32	74 €	58 €	44 €
	SCRCR07CA06	8095	8099	CC...0602...	20	7	9	28	74 €	58 €	44 €
	SCRCR10CA09	8098	8102	CC...09T3...	40	10	14	50	97 €	82 €	75 €
	SCRCR12CA12	8101	8105	CC...1204...	50	12	20	55	94 €	99 €	83 €
	SCSPR06CA05	8104	8108	CP...0502...	20	6	5,5	25	74 €	58 €	44 €
	SCSCR07CA06	8107	8111	CC...0602...	20	7	9	31	74 €	58 €	44 €
	SCSCR08CA06	8110	8114	CC...0602...	25	8	10	32	74 €	58 €	44 €
	SCSCR10CA09	8113	8117	CC...09T3...	40	10	14	50	97 €	82 €	75 €
	SCSCR12CA12	8116	8120	CC...1204...	50	12	20	55	94 €	99 €	83 €
	SCTPR06CA05	8119	8123	CP...0502...	20	6	5,5	25	74 €	58 €	44 €
	SCTCR07CA06	8122	8126	CC...0602...	20	7	9	31	74 €	58 €	36 €
	SCTCR08CA06	8125	8129	CC...0602...	25	8	6	32	74 €	58 €	44 €
	SCTCR10CA09	8128	8132	CC...09T3...	40	10	14	50	97 €	82 €	75 €
	SCTCR12CA12	8131	8135	CC...1204...	50	12	20	55	94 €	99 €	83 €

9

Lieferzeit ab Lager

Zwischenverkauf vorbehalten

delivery time from stock

Zwischenmaße/Sonderausführung möglich/special on request

passende Bohrstangen jederzeit/suitable boring bars o.request

Lieferumfang: mit allen Einbauteilen



Holder will be supplied complete

**Einbauhalter
Kurzklemmhalter
Cartridges**

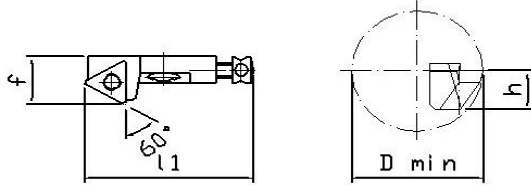
**Klemmsystem S
Clamping system Screw**

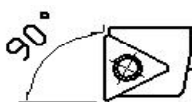

45°, 60°, 75°, 90°
für TCMT 090204 1102004 16T304

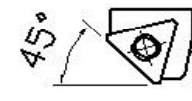
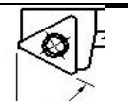
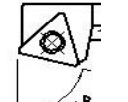
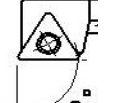
Bezeichnung Designation	Art.Nr / Code		Plattengröße Index. inserts	D min	h	f	l1	Preis/St		
	R	L						2 St	ab 5	ab 15
 90° STFCR/L 08CA09	8200	8201	TC...0902...	25	8	10	32	92 €	74 €	58 €
	8203	8204	TC...1102...	--	10	14	50	94 €	99 €	75 €
	8206	8207	TC...16T3...	--	12	20	55	94 €	99 €	83 €
 60° STWCR/L 08CA09	8206	8210	TC...0902...	25	8	10	27,7	92 €	74 €	58 €
	8209	8213	TC...1102...	--	10	14	50(44)	94 €	99 €	75 €
	8212	8216	TC...16T3...	--	12	20	55(45)	94 €	99 €	83 €
 45° STSCR/L 08CA09	8215	8219	TC...0902...	25	8	10	26	92 €	74 €	58 €
	8218	8222	TC...1102...	--	10	14	50(58)	94 €	99 €	75 €
	8221	8225	TC...16T3...	--	12	20	55(45)	94 €	99 €	83 €
 60° STTCR/L 08CA09	8224	8228	TC...0902...	25	8	10	32	92 €	74 €	58 €
	8227	8231	TC...1102...	--	10	14	50(41)	94 €	99 €	75 €
	8230	8234	TC...16T3...	--	12	20	55(45)	94 €	99 €	83 €
 75° STRCR/L 08CA09	8233	8237	TC...0902...	25	8	10	32	92 €	74 €	58 €
	8236	8240	TC...1102...	--	10	14	50(40)	94 €	99 €	75 €
	8239	8243	TC...16T3...	--	12	20	55(41)	94 €	99 €	83 €
 90° STGCR/L 08CA09	8242	8246	TC...0902...	25	8	10	32	92 €	74 €	58 €
	8245	8249	TC...1102...	--	10	14	50	94 €	99 €	75 €
	8248	8252	TC...16T3...	--	12	20	55	94 €	99 €	83 €

**Lieferzeit ab Lager
Zwischenverkauf vorbehalten**
delivery time from stock

**Zwischenmaße/Sonderausführung möglich/special on request
passende Bohrstangen jederzeit/suitable boring bars o.request**

Lieferumfang: mit allen Einbauteilen
Holder will be supplied complete

Wendepplatten
90° Eck-Schafffräser
90° Endmills



für Dreh/Fräswendepplatte
CCMT 060204
CCMT 060208

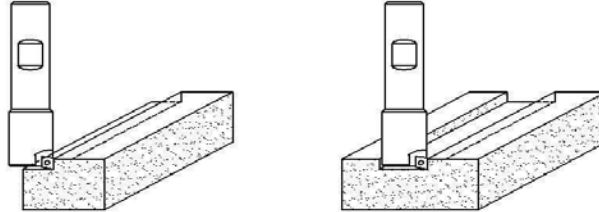

	Ø	L1	L2	L2	Zähne Teeth	Art.Nr Code	Preis
	8	12	45	90	1	8600	85 €
	9	12	45	90	1	8602	85 €
	10	12	45	90	1	8604	85 €
	11	12	45	90	1	8606	85 €
	12	12	45	90	1	8608	85 €
	13	12	45	90	1	8610	85 €
	14	--	45	90	2	8612	94 €
	15	--	45	90	2	8614	94 €
	16	--	45	90	2	8616	94 €
	17	--	45	90	2	8618	94 €
	18	--	45	90	2	8620	94 €
	19	--	45	90	2	8620	94 €
	20	--	45	90	3	8622	104 €
	21	--	45	90	3	8624	104 €
	22	--	45	90	3	8626	104 €
	23	--	45	90	3	8628	104 €
	24	--	45	90	3	8630	104 €
	25	--	45	90	3	8632	104 €
	30	--	45	90	4	8634	114 €
	32	--	45	90	4	8636	114 €

Zwischenmaße/Sonderausführung möglich/special on request

auch mit CCMT 09T304 oder 09T308

Lieferumfang: mit allen Einbauteilen

Holder will be supplied complete

Lieferzeit ab Lager

Zwischenverkauf vorbehalten

delivery time from stock



Hindenburgstr. 9/1
D-89610 Oberdischingen

Telefon (0 73 05) 95 66 29-0
Telefax (0 73 05) 95 66 29-9
IR-tools@t-online.de
www.IR-tools.de

Senk-Fas-Werkzeug

chamfering tool

kleine
Fräswerkzeuge

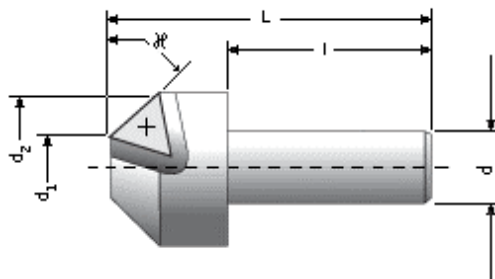
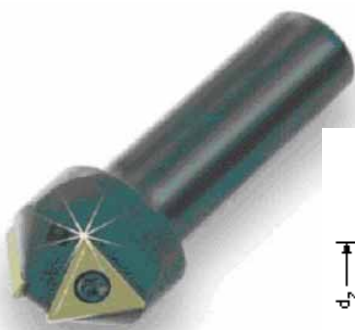

Z=1

Bezeichnung	d ₁	d ₂	dh ₆	L	l	H ₀	Spannfläche	Z	WS-Platte
05-12-45R	5	18	12	55	35	45	nein	1	TCMT 110204
05-12-45L	5	18	12	55	35	45	nein	1	TCMT 110204
07-12-45R	7	20	12	55	35	45	nein	1	TCMT 110204
07-12-45L	7	20	12	55	35	45	nein	1	TCMT 110204
10-12-45R	10	23	12	55	35	45	nein	1	TCMT 110204
10-12-45L	10	23	12	55	35	45	nein	1	TCMT 110204
10-16-45R	10	23	16	68	48	45	DIN 1835 B	1	TCMT 110204
10-16-45L	10	23	16	68	48	45	DIN 1835 B	1	TCMT 110204
10-20-45R	10	23	20	70	50	45	DIN 1835 B	1	TCMT 110204
10-20-45L	10	23	20	70	50	45	DIN 1835 B	1	TCMT 110204

Z=2

Bezeichnung	d ₁	d ₂	dh ₆	L	l	H ₀	Spannfläche	Z	WS-Platte
05-12-45 R2	5	19	12	55	35	45	nein	2	TCMT 110204
07-12-45 R2	7	21	12	55	35	45	nein	2	TCMT 110204
10-12-45 R2	10	24	12	55	35	45	nein	2	TCMT 110204
10-16-45 R2	10	24	16	68	48	45	DIN 1835 B	2	TCMT 110204
10-20-45 R2	10	24	20	70	50	45	DIN 1835 B	2	TCMT 110204

Lieferung ab Lager

del. From stock

Auch andere Abmessungen auf Anfrage lieferbar.

Other Dimensions on request available.

Schwermetall Bohrstangen - Preis auf Anfrage

Densimet boring bar - please request the price

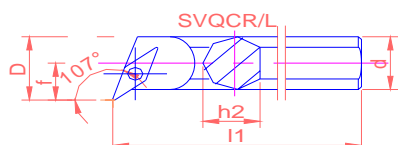
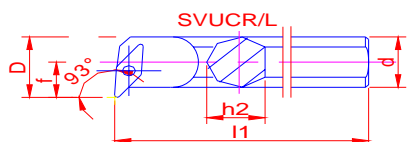
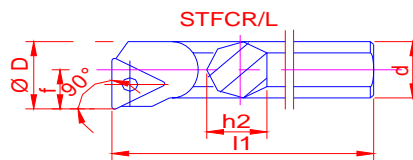
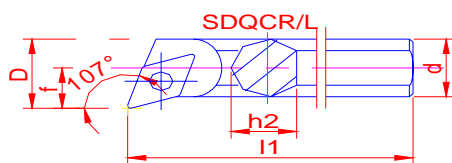
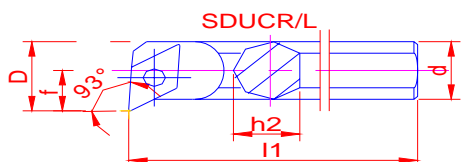
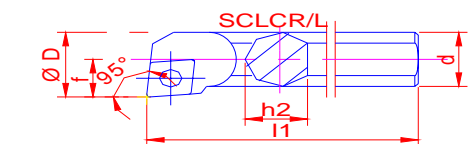

ISO	Abmessungen					Platte	Schraube
	d	h2	l1	f	D		
H08H SCLCR/L 06	8	7	100	5	11	CC__0602__	M2,5 x 6 T07
H10K SCLCR/L 06	10	9	125	7	14	"	"
H12K SCLCR/L 06	12	11	125	9	17	"	"
H12K SDUCR/L 07	12	11	125	9	17	DC__0702__	"
H16M SDUCR/L 07	16	15	150	11	21	"	"
H12K SDQCR/L 07	12	11	125	9	17	DC__0702__	"
H16M SDQCR/L 07	16	15	150	11	21	"	"
H08H STFCR/L 09	8	7	100	5	11	TC__0902__	M2,2 x 5 T07
H10K STFCR/L 09	10	9	125	7	14	TC__1102__	M2,5 x 6 T07
H12K STFCR/L 11	12	11	125	9	17	"	"
H16M STFCR/L 11	16	15	150	11	21	"	"
H10K SVUCR/L 07	10	9	125	7	14	VC__0702__	
H12K SVUCR/L 07	12	11	125	9	17	"	
H16M SVUCR/L 11	16	15	150	11	21	VC__1103__	M2,5 x 6 T07
H10K SVQCR/L 07	10	9	125	7	14	VC__0702__	
H12K SVQCR/L 07	12	11	125	9	17	"	
H16M SVQCR/L 11	16	15	150	11	21	VC__1103__	M2,5 x 6 T07

Lieferzeit ca. 3-4 AW
delivery time appr. 3-4 weeks

Lieferumfang: mit Klemmschraube
Holder will be supplied with one clamping screw
Auch andere Abmessungen auf Anfrage lieferbar.
Other Dimensions on request available.

**Norm
ist
normal.
Wir
wollen
besser
sein...**

IR
Werkzeuge
GmbH **IR**

**Wollen Sie
rationalisieren?**

**Benötigen Sie
Sonderwerkzeuge?**

Wir fertigen Sonderwerkzeuge mit Klemm- oder Wendeplatten nach Ihren Wünschen.

Wir bauen Ihnen auch mehrere Wendeschneidplatten ein.

Innere Kühlmittelzuführung auf Wunsch.

Die Werkzeuge werden nach den DIN bzw. ISO Normen gefertigt. Wir bieten kurze Lieferzeiten und günstige Preise.

Sprechen Sie mit uns, oder senden Sie uns Ihre Zeichnung oder Skizze.

Sie erhalten kurzfristig unseren Werkzeugentwurf und ein Angebot.

Nutzen Sie unsere Erfahrung und Fachkompetenz. Für eine ausführliche Beratung stehen wir jederzeit zur Verfügung.

Fordern Sie uns!

Drehwerkzeuge

Schaft 8 x 8 bis 40 x 40
Ø 7 bis Ø 40, Länge bis 400 mm
Klemmhalter für Stechplatten
Stufenwerkzeuge

Schwermetallwerkzeuge

(schwingungsdämpfend)
zur Feinstbearbeitung
von Bohrungen ab Ø=7

Kurzklemmhalter

(Einbauhalter)
ab Spitzenhöhe 7 mm

Trägerwerkzeuge

für Kurzklemmhalter oder
für Kurzklemmhalter und
Wendeschneidplatten

Senkwerkzeuge, Stufenwerkzeuge, Ausdrehwerkzeuge

Fräser

Schaftfräser
Formfräswerkzeuge
Messerköpfe

IR
Werkzeuge
GmbH **IR**

Hindenburgstr. 9/1
D-89610 Oberdischingen

Telefon (0 73 05) 95 66 29-0
Telefax (0 73 05) 95 66 29-9
IR-tools@t-online.de
www.IR-tools.de

Technischer Fragebogen

technical Questionnaire

Kunde/Customer:

Telefon/Phone:

Ansprechpartner/Contact person:

Fax:

Ort/Town:

Kühlmittel / cooling medium:

Kühlmittelzuführung / coolant supply:

- von außen an das Werkzeug / externaly onto tool
- durch die Spindel / through spindle

Kühlmitteldruck, -menge / coolant pressure, -quantity

Werkzeug / tool:

Benennung / description

Schaft / shank

Maschine / machine:

Typ, Antriebsleistung

type, power requirements (kW)

Bearbeitung / machining:

- Horizontal / horizontal
- Vertikal / vertical

Werkzeug / tool:

- Rotierend / rotating
- Stehend / stationary

Schnittdaten / cutt. data:

- Fest / regular
- Variabel / variable

Vc (m/min.) n (U/min) / n (rpm)

f (mm/U) / f (mm/rev)

Spindelaufnahme / Spindle mounting,

Werkstückstoff / workpiece material:

Bezeichnung / description

Festigkeit / tensile strength (N/mm²)

- Kurzspanend / short-chipping
- Langspanend / long-chipping

Werkstück / workpiece:

Benennung / Component

Bohrtiefe / drilling depth

Gewünschte Toleranzen / required tolerances

- Unterbrochener Schnitt / intermittent cut

